

4237

Sent to us from from Laurie Rendall, Engineering
Case Program, Stanford University, California, !
to forward to you. With all good wishes.

*With the
Editor's Compliments*

THE AERONAUTICAL JOURNAL
THE ROYAL AERONAUTICAL SOCIETY
4 HAMILTON PLACE, LONDON, W1V 0BQ
Telephone: 01-499 3515-9

ECL 172A

ENGINEERING CASE LIBRARY

"THIS MUST BE DONE!" (A)

One morning in early May 1935, the secretary of the Cambridge University Air Squadron handed a private letter to a 28 year old R.A.F. officer taking his Mechanical Sciences Tripos at Cambridge. This letter was to change this man's life and to markedly change the future of aircraft. It was an ordinary looking letter from his friend, R. Dudley Williams, who had been a fellow cadet at Cranwell but had since been retired from the R.A.F. due to ill health.

"This is just a hurried note to tell you that I have just met a man who is a bit of a big noise in an engineering concern and to whom I mentioned your invention of an aeroplane, sans propeller as it were, and who is very interested. You told me some time ago that Armstrong's had or were taking it up and if they have broken down or you don't like them, he would, I think, like to handle it. I wonder if you would write and let me know."

"THIS MUST BE DONE!" (A)

Frank Whittle read his letter, stuffed it into his pocket, and dismissed it from his mind. The last five years of trying to interest the government and industry had completely discouraged him. He had allowed his 1930 patents on the jet engine to lapse in January when it had become due for renewal. The Contracts Directorate of the Air Ministry had informed him that there wasn't sufficient official interest for the ministry to pay the renewal fee of £5 (\$25) out of official funds. Whittle was convinced that the engine was "before its time". Because of family problems he could not afford the £5 fee and thus he had allowed the patent to lapse.

Frank Whittle was born in 1907 of Lancashire working class parents. As a youngster Frank helped his father in his small machine shop and acquired much practical experience in manufacturing. In school Whittle scraped through with the least possible effort spending his time pursuing only those subjects which interested him.

At age 20 he joined the Royal Air Force as an aircraft apprentice and received training as an aircraft rigger. At the end of his three years apprenticeship he became one of five to be awarded cadetships to the R.A.F. College at Cranwell due largely to his activities with model aircraft.

During his final year at Cranwell, Whittle was required to write a term thesis. His thesis attempted to predict the trends in aircraft design. B. M. Janes had just published a paper on "The Importance of Streamlining" which showed that at top speed in level flight two thirds of the power of present aircraft, even of a racer, was used in overcoming the drag due to turbulence which could be eliminated by better design of the airframe. Whittle concluded that if this drag could be reduced by streamlining and by flying at higher altitudes, the operational speed of aircraft could be greatly increased. He concluded that to meet future operational requirements aircraft would have to fly higher, faster and further. He was thinking in terms of speeds of 500 miles per hour at 40,000 feet at a time when operational fighters had a speed of 150 miles per hour at 10,000 feet. This led Whittle to consider unconventional means of propulsion. He discussed various power plants and their limitations, piston engine driven propellers, rocket propulsion, and turbine driven propellers.

Completion of the thesis and graduation from the R.A.F. College did not terminate his interest in high speed flight. As a student at the Wittering Flying School he continued his search for a suitable power plant for high speed, high altitude aircraft. He examined jet propulsion using a ducted fan driven by a conventional engine, including the burning of fuel in the outlet nozzle. This arrangement, as far as he could see, had little advantage over the conventional engine-propeller combination.

Toward the end of 1929 it suddenly occurred to Whittle to substitute a gas turbine for the piston engine in his jet. This naturally led him to consider the use of the same compressor for the turbine and the jet. This change meant that the compressor would have to have a much higher pressure ratio than previously considered, in fact, greater than had yet been produced by any blower manufacturer. The idea was so obvious and so simple, Whittle was at a loss to understand why he had not seen it earlier. A series of calculations soon satisfied him that this concept was truly superior to his earlier proposals.

In fact, the use of the exhaust of a gas turbine for jet propulsion had been proposed and patented by a Frenchman, M. Guillaume in 1921. Guillaume's patent was not taken up nor developed and the work was completely unknown to Whittle.

Whittle took his idea to Flying Officer W. E. P. Johnson, a former patent agent. Johnson took Whittle to their commanding officer, Group Captain Baldwin, who was impressed and arranged for a presentation to the Air Ministry. In a few days Whittle found himself at the Air Ministry explaining his ideas to W. L. Tweedie, the director of Scientific Research, and to Dr. A. A. Griffith.

A. A. Griffith was Britain's leading exponent of the gas turbine. Nine years earlier at the Royal Aircraft Establishment he had developed a theory of axial flow compressors and turbines based on the then new theory of airfoils. Griffith believed that he could design a sufficiently efficient gas turbine to make it practical for driving a propeller. In 1926 he proposed and received approval for "preliminary experiments to verify the theory" of an axial flow turbine for aircraft. Griffith's experiments were successful and by 1929 Griffith argued that an aircraft turbine could be built lighter and smaller than current piston engines. His suggestions were considered by the Aeronautical Research Committee, and although it was not recommended for construction, appropriations were made for

further experiments toward that end. Meanwhile, Griffith was transferred to the Air Ministry Laboratory at South Kensington where there were no facilities for such work. It was while at South Kensington that he was called in to assess Frank Whittle's proposals. Thus A. A. Griffith to whom the 22 year old flying cadet made his presentation was one of the foremost authorities on gas turbines in Britain at the time. Griffith later went on to develop the axial flow gas turbine for the Royal Aeronautical Establishment. Eventually at the government's suggestion he was hired by Rolls-Royce to head development of the superchargers for their outstanding Merlin engines.

The results of the meeting were depressing to Whittle. He learned that the Air Ministry did not consider the gas turbine as very practical. Griffith, although enthusiastic about the gas turbine, quietly pointed out certain over-optimistic assumptions and an error in Whittle's calculations that threw his conclusions in doubt.

Discouraged, Whittle returned to his calculations and after carefully revising them found a second error that effectively balanced out the first error so that the conclusions drawn were the same. His confidence in his original conclusions was restored.

The Air Ministry wrote a letter to Whittle pointing out that his proposal was a form of gas turbine, and that its successful development was considered to be impractical, because material did not presently exist capable of withstanding the combination of high stress and high temperature which would be necessary to achieve acceptably high efficiencies. These comments were based upon the Ministry's experience and with the state of the art of gas turbine development. Whittle's proposals at this time were based on thermodynamic and aerodynamic calculations. Outside of the general mechanical arrangement of parts no detail design of turbine elements had been made. Therefore the Air Ministry's comments were correct. No suggestions were made that the proposals would be reconsidered at some future time.

Whittle's case suffered very considerably from his youth, from lack of presence, as well as his lack of technical training and experience. This all made it impossible for him to overcome an opinion universally accepted by the leading engineers and scientists in the field.

At Johnson's urging Whittle filed a patent on his idea in January 1930. In accordance with regulations he informed the Air Ministry of his application. They replied that

there was no official interest in the patent and there was no suggestion of putting the patent on the secret list. Consequently eighteen months later the invention was published and available throughout the world. (Exhibit 1) These and other Whittle patent drawings eventually appeared in a German aeronautical magazine in 1939. (Exhibit 2)

On completion of his training as a flying instructor, Whittle was stationed at Digby Flying Training School. Here he continued developing his idea on the engine. He kept in touch with Johnson who helped him in attempting to interest commercial firms in his ideas. The two young officers when not engaged in their regular duties visited various firms. Many made careful reviews but concluded that, although the principles were sound, they would not be practical for some 10 years. Considering the depressed state of the economy at that time and the high long term investment required the firms could not be expected to do anything about the scheme.

British Thomson-Houston, (BTH), a turbine manufacturer, was one of the firms who showed considerable interest in Whittle's idea. Their chief turbine designer, E. F. Samuelson, and his deputy investigated the scheme thoroughly. They estimated that the development of such an engine would cost £60,000 (approximately \$300,000 at that time). They were not prepared to undertake such an investment, especially in the light of their awareness of the technical difficulties of successful gas turbine development and because of its sale application to aircraft which was not BTH field of activity.

Whittle's studies led him to appreciate that his scheme could only be successful if higher efficiencies could be achieved for the various components than were available at the time. He proposed and received patents on improvements on centrifugal compressors. These compressor improvements often took precedent over his jet engine proposals when talking to manufacturers partly because they represented a shorter development and had application in piston engine supercharging and partly because the success of the compressor development would strengthen his case for the jet-engine. This interest in compressors led to a paper on superchargers published in the Journal of the Royal Aeronautical Society and a patent with a fellow officer on the use of an independent engine for driving the supercharger of an aeroengine. Whittle's turbo-jet proposal required a compression ratio of 4:1 at an efficiency of 75%. The best supercharger then available

had a compression ratio of only 2:1 at an efficiency of only 62%.

Transferred to Felixstowe, Whittle was engaged as an experimental test pilot. Here his ideas were a frequent topic of conversation among his fellow officers, especially since Whittle was constantly attempting to interest the many manufacturer's representatives who visited the base in his scheme. They christened the jet engine "Whittle's Flaming Touch-hole" and invariably greeted him with "Well, how's the old flaming touch-hole?" It was at Felixstowe that Flying Officer R. Dudley Williams took an interest in the turbo-jet. He tried to help Whittle raise money to obtain American and foreign patents on it.

At this time Whittle collected his ideas on his jet-engine. He demonstrated on paper the increases in efficiency with altitude and showed that low temperatures would be beneficial to the engine's operation. His calculations estimated how range was affected by aircraft drag and altitude. From the beginning he conceived of the jet engine and the aircraft as a single system and recognized that the effectiveness and efficiency of both were interlinked, i.e., the reduction in aerodynamic drag would result in increased engine efficiency.

At Felixstowe, Whittle was involved in development flying in which he not only acted as test pilot but submitted a number of patentable ideas for improvement of the aircraft. As a permanent officer he chose to specialize in engineering. His preliminary examination results at officers engineering school were so outstanding that he was allowed to enter the course at a senior level and finish the course in eighteen months instead of the regular two years. He did so well that the Air Ministry gave special approval to his application for advance training at Cambridge, a discontinued policy of regularly sending selected candidates for the engineering course.

Whittle was a little older than his student contemporaries, but he was to later recall, "I found that it was, in many ways, a big advantage to have gone to the university after several years of practical experience, because I had acquired a strong desire to know the explanation of many of the phenomena I had encountered during this experience. Many items of knowledge which had great practical significance for me must have seemed relatively academic to those who had gone to university direct from school."

With Williams' letter in his hand, Whittle's first instincts were to dismiss the matter because of the lapsed patent. On thinking it over he decided that it might be worth encouraging Williams. Even if nothing came of the turbo-jet, their efforts might be able to provide contacts for some of the other patents that Whittle had in mind.

Shortly thereafter, Whittle met with Williams and J. C. B. Tinling, another ex-R.A.F. officer. The three came to an arrangement whereby they would attempt to raise financial backing for the turbo-jet development. Whittle explained about the patent lapse but proposed a series of patentable improvements which would strengthen their position. Whittle recognized that he was on shaky ground but it was the only negotiating position they had.

An agreement was arrived at whereby Williams and Tinling would cover further patents and other expenses and would act as Whittle's agents. In return they were each to receive one quarter of any profits realized. Patents were filed on a number of additions and changes to Whittle's basic ideas.

Whittle tried to have changed a standard Air Ministry agreement which gave the government free use of all inventions made by serving officers. Despite the fact that the government showed no interest they refused to consider any change in this requirement.

For a number of months Williams and Tinling were unsuccessful in their attempts to raise capital. In October 1935 they met M. L. Bramson, a well-known independent aeronautical engineer. This caused Whittle some concern. Whittle's awareness of his shaky position as to patent protection and his previous experiences had led to one fundamental policy: under no circumstances were they to go to anyone connected with the aircraft industry.

Bramson introduced them to O. T. Falk and Company, Ltd., an investment company set up by the directors because they were conscious that there was a real national problem growing up in England due to the increasing tendency of investors to seek security above all in their investments. Thus Falk and Partners, although not specialists in financing of new technical developments, were particularly receptive to such ideas, and had already financed a few other blue sky projects.

The man to whom Bramson and Whittle took their ideas was L. L. Whyte, a leading partner in the firm. Whyte was unusually well equipped to take an interest; he was a

scientist, philosopher and banker - an unusual combination. He had been trained as a physicist at Cambridge, was a banker by profession, and a philosopher by inclination.

Whyte listened to the ideas presented to him. He was impressed and was favorably inclined toward the project. He told Whittle he was prepared to recommend financial support for the project provided that an independent engineering assessment was made and that the assessment was favorable.

By whom and how would the assessment be made?

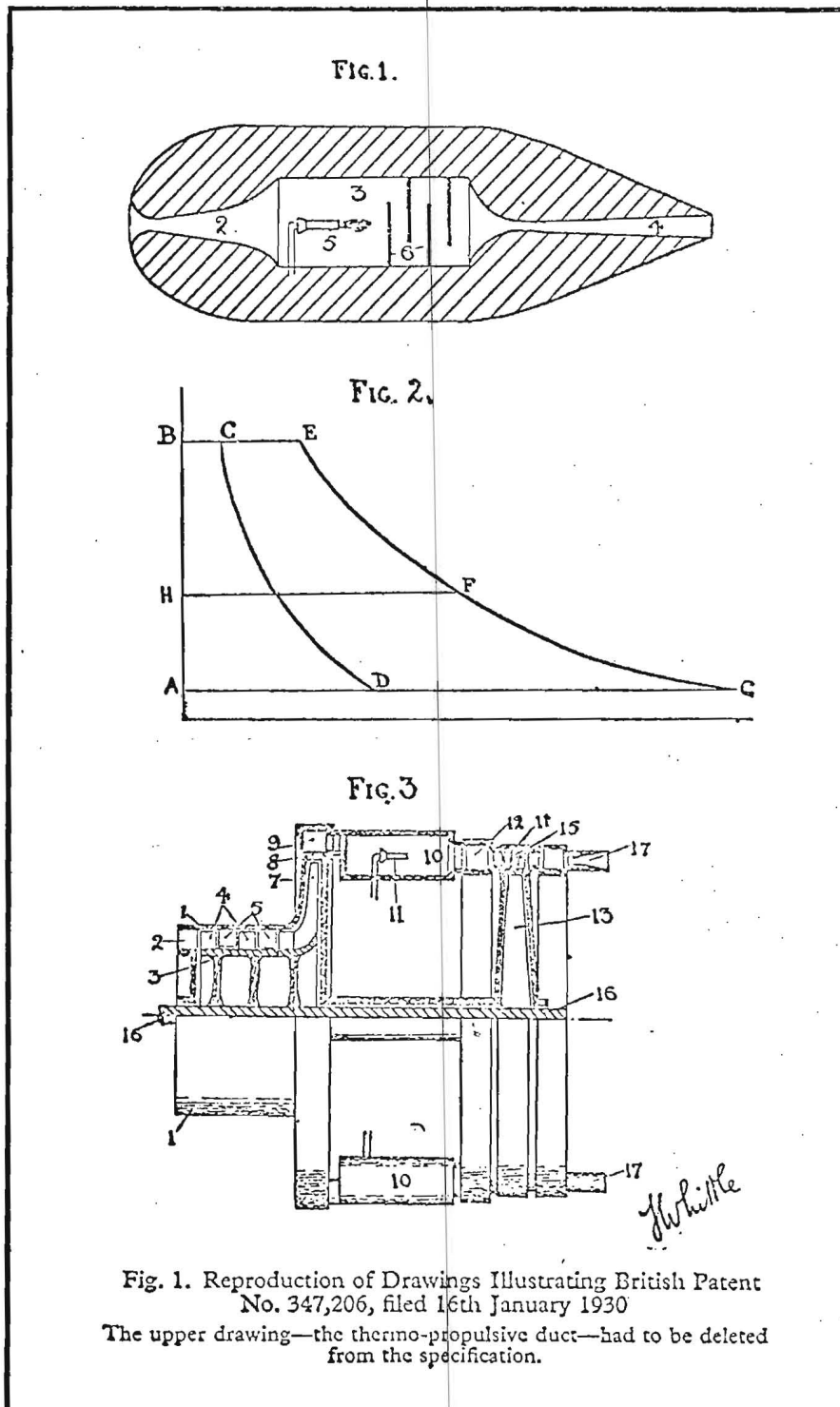
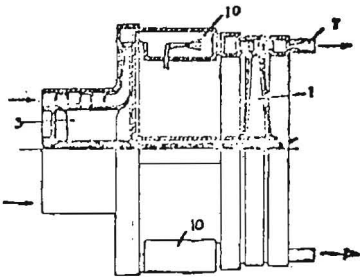

Fig. 1. Reproduction of Drawings Illustrating British Patent No. 347,206, filed 16th January 1930
 The upper drawing—the thermo-propulsive duct—had to be deleted from the specification.

Abb. 14. Whittle 1935.
Brennstrahl treibt Kom-
pressor-Gasturbine.



Translation

Fig. 14. Whittle 1935. Exhaust Jet Drives a Gas Turbine Compressor

Abb. 14.



Abb. 65.



Abb. 62.

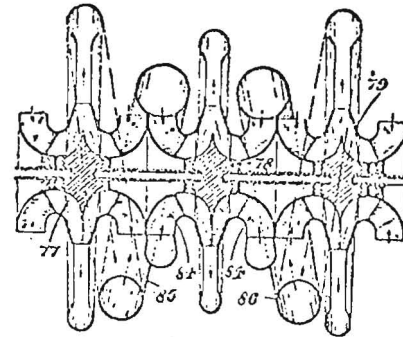

Abb. 63.

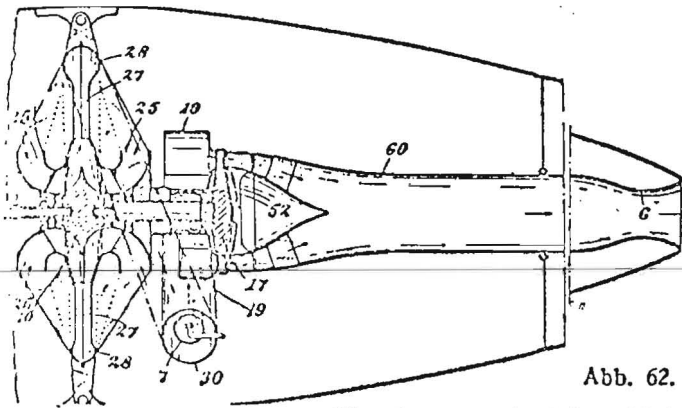

Abb. 64.

Abb. 62—65. Whittle 1935; Heizluftstrahltriebwerk mit Axialturbine.

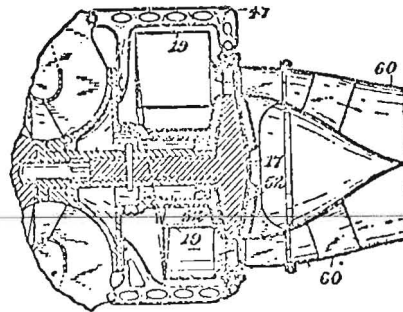
Translation Figs. 62—65. Whittle 1935: Thermal Jet Propulsion with Axial Turbine

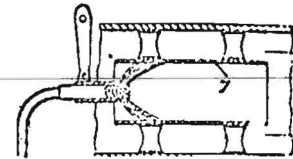

Abb. 66. Whittle 1936; Zwillingstriebwerk.

Translation

Fig. 66. Whittle 1936: Twin Propulsion System

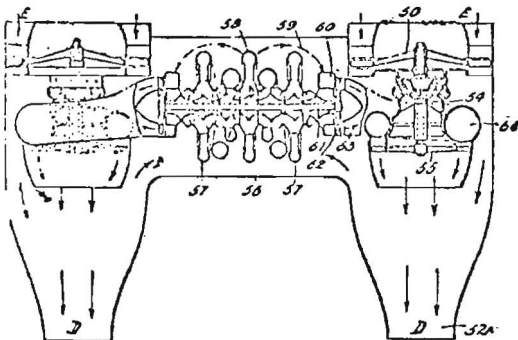

Abb. 67. Whittle 1936; Heizluftstrahltriebwerk mit Kolbenmotor und Turbine.

Translation

Fig. 67. Whittle 1936: Thermal Jet Propulsion with Piston Engine and Turbine

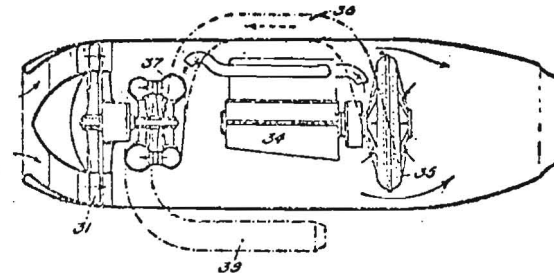